

PROJECT	QUANTITY	ITEM NO
---------	----------	---------

Heated Merchandisers

Full-serve or self-serve

HMR 104 4 well



HMR 104 4-well self-serve heated merchandiser

Henny Penny HMR heated merchandisers are designed to provide operators with the ultimate in flexibility and performance for hot food display and service.

The HMR series lets operators choose and combine full-serve and self-serve heated merchandisers in five different widths.

The HMR 104 4-well merchandiser comes as a stand-alone full-serve or self-serve unit. Perfect for intermediate retail hot food programs.

Full-serve sections feature THERMA-VEC[®], the exclusive even heating process developed by Henny Penny to keep foods at precise temperatures for a more appetizing and attractive display. No more cold spots or fogged glass!

Upper and lower heating are

THERMA-VEC[®] Even Heat Process eliminates hot/cold spots and fogging by gently circulating heat from lower elements evenly under pans, up through vents front and back, and over food. Sensors adjust temperature and air flow promptly to compensate for heat loss when serving.

independently controlled, with separate controls for upper radiant heat over each well.

Two curved front glass profiles are available.

See separate data sheets for 3, 5, 6, and 7-well models, and for merchandiser bases available in profile or pedestal styles and in several heights and colors.

Standard features

- 4-well model available as full-serve or self-serve unit
- Exclusive Therma-Vec[®] Even Heat Process holds food at precise temperatures with no cold spots or fogging
- High-quality tempered glass front, sides and rear
- Choose front glass profile:
 - Henny Penny curved
 - Advantage curved (matches Tyler Advantage[®] series)
- Front glass lifts easily for cleaning and closes gently on gas springs
- Upper radiant heat with separate temperature control and food probe display for each well
- Lower heat and water pan temperature controlled separately
- Control lockout to prevent accidental changes
- Water pan humidity with built-in low-water indicator
- Brilliant halogen lamps for attractive food presentation
- Separate switches for power and lighting
- Removable mirrored sliding glass rear doors
- Mirrored or clear side glass (clear side glass, only, for CE units)
- Sneeze guard on self-serve glass
- Fold-down plastic cutting board
- Stainless steel construction for easy cleaning and long life

Accessories shipped with unit

- Adjustable pan supports for 1 full-size and 1 third-size steam table pan per full service well
- Stainless steel insert for self-serve units
- Food temperature probes
- Water pan

Optional accessories

- Modular wire shelf system for adding mezzanine tier
- Wire shelf for 3-well section
 - Wire shelf for 2-well section
 - Pan support with guide rail

<input type="checkbox"/> APPROVED	<input type="checkbox"/> APPROVED AS NOTED	<input type="checkbox"/> RESUBMIT
AUTHORIZED SIGNATURE		DATE



Heated Merchandisers

Full-serve or self-serve

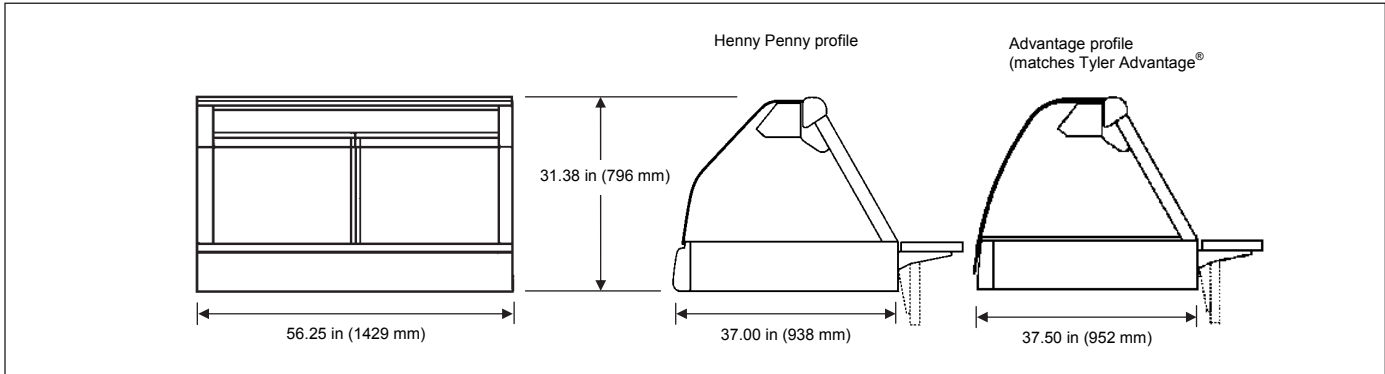
HMR 104 4 well

Dimensions

Height	31.38 in (796 mm)
Width	56.25 in (1429 mm)
Depth	37.00 in (938 mm) Henny Penny profile 37.50 in (952 mm) Advantage profile

Crated

Length	63 in (1600 mm)
Depth	49 in (1240 mm)
Height	40 in (1015 mm)
Volume	71 ft ³ (2.0 m ³)
Weight	440 lb (200 kg) may vary

Capacity

Full-serve	4 wells, 1 full-size pan + 1 third-size pan per well up to 4 in (102 mm) deep
Self-serve	4-well insert 26.75 x 49.50 in (679 x 1257 mm)
	<input type="checkbox"/> Flat
	<input type="checkbox"/> 0.38 in (10 mm) deep
	<input type="checkbox"/> 2.00 in (51 mm) deep

Required clearances

Top	15 in (381 mm) raised front glass
Back	9 in (229 mm) cutting board

Electrical
 Low High

4-well	Volts	Phase	Hertz	kW	Amps	kW	Amps	Wire
Self serve	120/208	1	50/60	2.77	13.3	3.77	18.1	3+G
	120/240	1	50/60	2.77	11.5	3.95	16.4	3+G
	220-240	1	50/60	3.20	13.3	4.38	18.2	2+G
	120/208	3	50/60	2.77	9.2	3.77	11.1	4+G
	120/240	3	50/60	2.77	8.2	3.95	10.1	4+G
	380-415	3	50/60	3.20	5.4	4.38	6.8	3NG
Full serve	120/208	1	50/60	3.34	16.1	4.34	20.9	3+G
	120/240	1	50/60	3.38	14.1	4.56	19.0	3+G
	220-240	1	50/60	3.81	15.9	4.99	20.8	2+G
	120/208	3	50/60	3.34	9.9	4.34	13.0	4+G
	120/240	3	50/60	3.38	8.7	4.56	12.3	4+G
	380-415	3	50/60	3.81	5.4	4.99	7.8	3NG



Bidding specifications

Provide Henny Penny model HMR 104 4-well heated merchandiser in full-serve or self-serve models.

Unit shall incorporate:

- Full-serve model with full front glass, adjustable stainless steel pan supports
- Self-serve model with partial front glass, flat stainless steel insert
- Choice of front glass profiles
- All stainless steel and tempered glass
- Mirrored side glass and rear sliding doors (CE units are clear glass)
- THERMA-VEC® Even Heating Process for maintaining precise food temperatures evenly throughout the case
- Upper radiant heat separately controlled over each well, upper and lower heat independently controlled
- Water pan humidity with low-water warning light
- Merchandiser bases sold separately

Laboratory certifications

Power cord and plug included for USA and Canada	
120/208 V 1 Phase 120/240 V 1 Phase	NEMA L14-30P 
120/208 V 3 Phase	NEMA L21-20P 
For all other electrical configurations, power cord and plug must be installed on site by a qualified electrician.	

Continuing product improvement may subject specifications to change without notice.

24 Hour Technical Support:
Henny Penny Technical Service
800.417.8405
technicalservices@hennypenny.com

Henny Penny Corporation
PO Box 60 Eaton OH 45320 USA
+1 937 456.8400 800 417.8417
+1 937 456.8434 Fax 800 417.8434 Fax
www.hennypenny.com

HENNY PENNY
Engineered to Last