

PROJECT	QUANTITY	ITEM NO
---------	----------	---------

FlexFusion™ combi oven

Space\$aver™

FSE 605 Electric



Chef'sTouch control: Just tap and swipe to run automated cooking and operating apps

Henny Penny FlexFusion combi ovens combine different cooking methods into one piece of equipment with the flexibility to cook nearly everything on your menu to perfection.

The FlexFusion Space\$aver combi incorporates powerful yet highly energy-efficient boilerless steam generation into a compact tabletop unit less than 22 inches wide! Perfect for lower cost, lower-volume operations. This system instantly adds or eliminates the precise amount of moisture needed to maintain desired cooking conditions... all while saving more energy and water than ever through an improved heat exchange design.

What really sets FlexFusion apart is its ease of use. The Space\$aver features Chef'sTouch, an intuitive control system with a durable 7-inch touch/swipe screen that makes cooking with FlexFusion as easy as

Popular FlexFusion built-in Apps:

- **PerfectHold**—Automatically switches to Hold when done cooking
- **TimeToServe**—Tells you when to load different items so they are all done at the same time
- **FamilyMix**—Shows which items can be cooked together
- **GreenInside**—Displays energy and water use for each cooking program
- **CombiDoctor**—Runs system self-diagnostics and displays results

using a smart phone! Just tap the app for everything from cook-and-hold to cleaning and trouble-shooting.

WaveClean™ self-cleaning system, multi-sensor core temperature probe and USB port are standard.

Removable tilt-resistant rails accept full-size steam table pans or half-size sheet pans and grids.

Standard Features

- Chef'sTouch™ Control System for Automatic or easy manual cooking
 - Durable 7-inch high resolution capacitive touch screen
 - Full-color touch/swipe display
 - Create and select from up to 350 custom cooking programs of 20 steps each
 - Select and use apps for cooking, serving convenience, cleaning, diagnostics and more
 - Use ClimaSelect Plus to set and maintain humidity levels at 10% increments from 0% to 100% RH
 - Adjust individual settings before or during cooking
 - Core temperature probe
 - Temperature in °F or °C
 - Choose language for operations and service diagnostics
- 5 or 6-level removable pan rack with tilt-resistant rails
- DynaSteam2 precision boilerless steam generation with built-in energy-saving heat transfer
- 5-speed auto-reverse fan for fast, even cooking throughout the cabinet
- Powerful high-efficiency motor uses up to 15% less energy
- Improved WaveClean® self-cleaning system uses 36% less water
- 316S11 stainless steel interior cabinet with coved corners
- 1 mm stainless steel exterior
- Full perimeter door seal
- Filterless grease extraction
- Energy efficient triple-pane glass
- USB port for convenient download of programs, diagnostic messages or HACCP data

Options, accessories*

- Multi-point temperature probe
 - Barcode scanning app
 - Stands and wall bracket
 - Left-hinged door
 - Alternate voltages
- Choose rail configuration:
- 5 rails
 - OR
 - 6 rails

*See separate accessories data sheets for details

<input type="checkbox"/> APPROVED	<input type="checkbox"/> APPROVED AS NOTED	<input type="checkbox"/> RESUBMIT
AUTHORIZED SIGNATURE		DATE



FlexFusion™ combi oven

SpaceSaver™

FSE 605 Electric

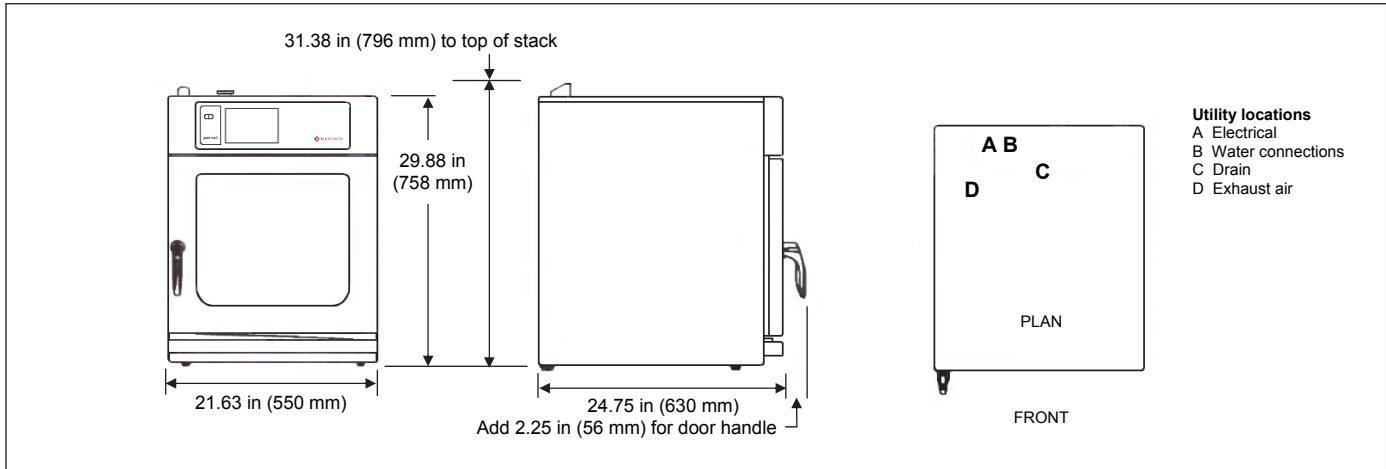
**Dimensions**

Height	29.88 in (758 mm)
	31.38 in (796 mm) top of stack
Width	21.63 in (550 mm)
Depth	24.75 in (630 mm)

Crated

Length	29 in (740 mm)
Depth	25 in (620 mm)
Height	34 in (860 mm)
Volume	14 ft ³ (0.4 m ³)
Weight	155 lb (70 kg)

Required clearances

Left	20 in (500 mm) service access
Right	2 in (50 mm) air flow
Back	2 in (50 mm) air flow, utilities
Front	28 in (700 mm) door open

Electrical

Volts	Phase	Hertz	kW	Amps	Wire
208	3	60	7.4	14.8	3+G

Laboratory certifications**Heat**

Electric 3.6 kW or 5.5 kW connected load
 Max temperature 572°F (300°C)

Water

0.75 in standard cold water connection
 0.75 in soft water connection
 1.5 in (40 mm) drain

Capacity

- 5 two-thirds size 2.5 in (65 mm) steam table pans
OR
- 6 two-thirds size 2.0 in (50 mm) steam table pans

Cooking mode profiles

Steaming/moist heat
 86-266°F (30-130°C)
 Low and high temperature steaming
 Convection cooking/dry heat
 86-572°F (30-300°C) electric
 Active humidity reduction
 Combination/dry + moist heat
 86-482°F (30-250°C)
 Manual or automatic humidity control
 between 0 and 100% RH
 Rethermalizing/dry + moist heat
 86-356°F (30-180°C)
 Special fan speed function, banqueting programs

Bidding specifications

Provide Henry Penny FlexFusion SpaceSaver™ model FSE 605 electric combi oven, designed to cook with steaming/moist heat, convection/dry heat, or a combination of dry and moist heat, and holding up to 5 two-thirds size steam table pans 2.5 in (65 mm) or 6 two-thirds size steam table pans 2.0 in (50 mm) pans on removable tilt-resistant rails.

Unit shall incorporate:

- Chef's Touch Control System featuring protected full-color capacitive touch screen with automatic and manual cooking capability, ClimaSelect Plus humidity control and designated pre-loaded apps
- Boilerless DynaSteam2 Technology with precise humidity generation and heat exchange
- Variable speed, auto reverse fan that moves air in alternating directions for more even heating
- Automated WaveClean® self-cleaning system
- Seamless stainless steel cooking chamber, full-perimeter door seal and triple-pane glass for energy efficiency
- Cabinet interior: 316S11 stainless steel
cabinet exterior: 1 mm stainless steel

Continuing product improvement may subject specifications to change without notice.

24 Hour Technical Support:
 Henry Penny Technical Service
 800.417.8405
technicalservices@henrypenny.com

Henry Penny Corporation
 PO Box 60 Eaton OH 45320 USA
 +1 937 456.8400 800 417.8417
 +1 937 456.8434 Fax 800 417.8434 Fax
www.henrypenny.com

HENNY PENNY
 Engineered to Last